

ASSEMBLY INSTRUCTIONS
FOR
SUPERLITE 6 BIG BRAKE FRONT HAT KIT
WITH 12.90" DIAMETER VENTED ROTOR

1998 - 2002 CAMARO / FIREBIRD

PART NUMBER GROUP

140-7763

**DISC BRAKES SHOULD ONLY BE INSTALLED BY SOMEONE
EXPERIENCED AND COMPETENT IN THE INSTALLATION
AND MAINTENANCE OF DISC BRAKES**

READ ALL WARNINGS

WARNING

IT IS THE RESPONSIBILITY OF THE PERSON INSTALLING ANY BRAKE COMPONENT OR KIT TO DETERMINE THE SUITABILITY OF THE COMPONENT OR KIT FOR THAT PARTICULAR APPLICATION. IF YOU ARE NOT SURE HOW TO SAFELY USE THIS BRAKE COMPONENT OR KIT, YOU SHOULD NOT INSTALL OR USE IT. DO NOT ASSUME ANYTHING. IMPROPERLY INSTALLED OR MAINTAINED BRAKES ARE DANGEROUS. IF YOU ARE NOT SURE, GET HELP OR RETURN THE PRODUCT. YOU MAY OBTAIN ADDITIONAL INFORMATION AND TECHNICAL SUPPORT BY CALLING WILWOOD AT (805) 388-1188, OR VISIT OUR WEB SITE AT WWW.WILWOOD.COM. USE OF WILWOOD TECHNICAL SUPPORT DOES NOT GUARANTEE PROPER INSTALLATION. YOU, OR THE PERSON WHO DOES THE INSTALLATION MUST KNOW HOW TO PROPERLY USE THIS PRODUCT. IT IS NOT POSSIBLE OVER THE PHONE TO UNDERSTAND OR FORESEE ALL THE ISSUES THAT MIGHT ARISE IN YOUR INSTALLATION.

RACING EQUIPMENT AND BRAKES MUST BE MAINTAINED AND SHOULD BE CHECKED REGULARLY FOR FATIGUE, DAMAGE, AND WEAR.



WARNING

DO NOT OPERATE ANY VEHICLE ON UNTESTED BRAKES!
SEE MINIMUM TEST PROCEDURE WITHIN

ALWAYS UTILIZE SAFETY RESTRAINT SYSTEMS AND ALL OTHER AVAILABLE SAFETY EQUIPMENT WHILE OPERATING THE VEHICLE.

IMPORTANT • READ THE DISCLAIMER OF WARRANTY INCLUDED IN THE KIT.

NOTE: Some cleaners may stain or remove the finish on brake system components. Test the cleaner on a hidden portion of the component before general use.

Important Notice - Read This First

Before any tear-down or disassembly begins, review the following information:

- Review the wheel clearance diagram (figure 2, page 3) to verify that there is adequate clearance with the wheels you will be using with the installation.
- Front brake kits do not include flex lines. OEM brake lines will not adapt to Wilwood calipers. Check the assembly instructions, or associated components section for brake line recommendations before assembly. In addition, Wilwood offers an extensive listing of brake lines and fitting on our web site: www.wilwood.com.
- Due to OEM production differences and other variations from vehicle to vehicle, the fastener hardware and other components in this kit may not be suitable for a specific application or vehicle.
- It is the responsibility of the purchaser and installer of this kit to verify suitability / fitment of all components and ensure all fasteners and hardware achieve complete and proper engagement. Improper or inadequate engagement can lead to component failure.

Exploded Assembly Diagram

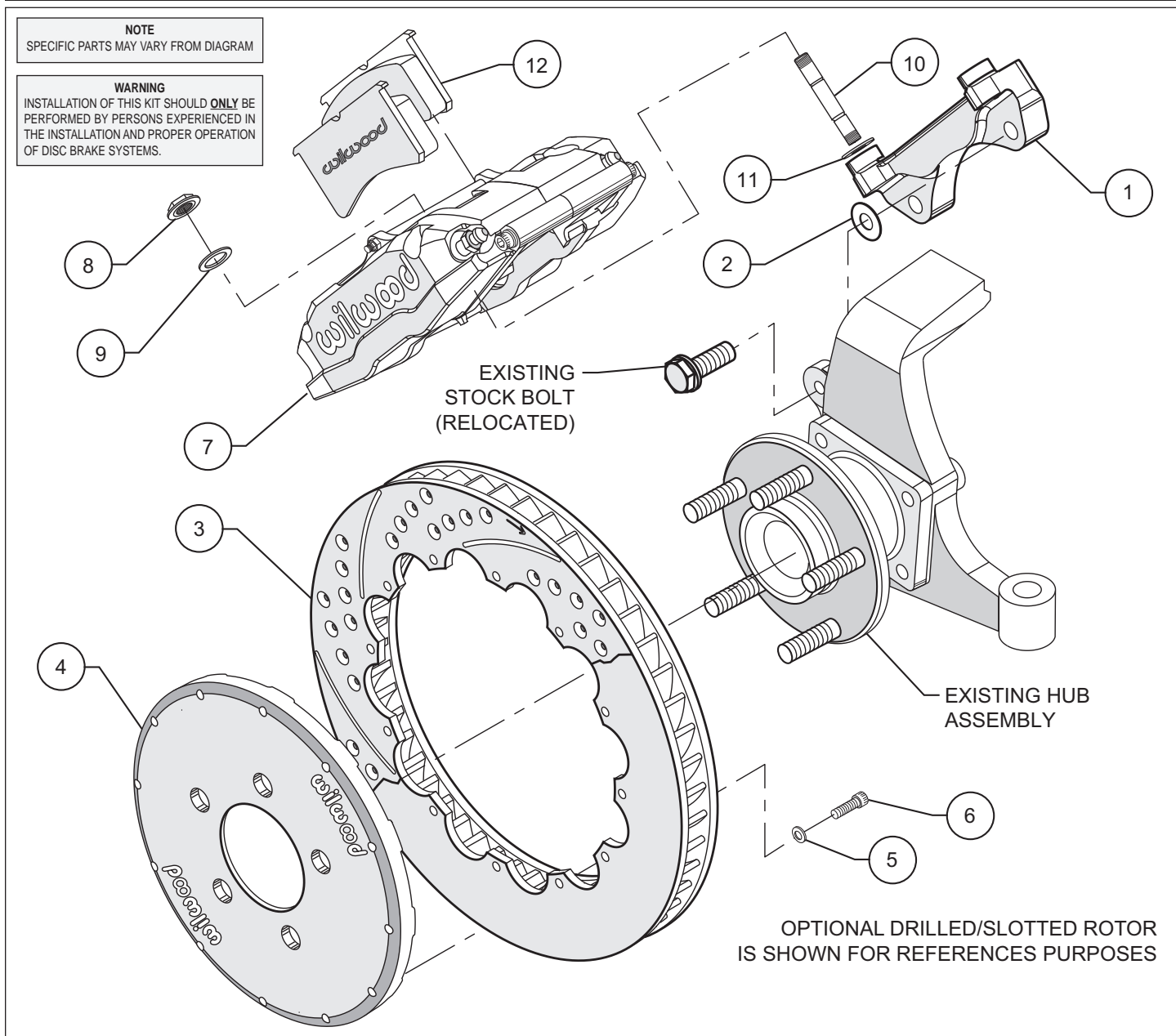

Figure 1. Typical Installation Configuration

Parts List

<u>ITEM NO.</u>	<u>PART NO.</u>	<u>DESCRIPTION</u>	<u>QTY</u>
1	250-7690	Bracket, Caliper Mounting	2
2	240-6320	Washer Flat, 1-1/32 inch	8
3	160-4564/65	Rotor, 1.25" Thick x 12.90" Dia, 12 x 8.75" Bolt Circle	2
3A	160-7172/73	Rotor, Drilled and Slotted, one each, right and left hand	2
4	170-6837	Hat	2
5	240-2509	Washer, 1/2 inch	12
6	230-6737	Bolt, 1/4-20 x 1.00 Long, 12 Point Stainless	12
7	120-7761/62-RS	Caliper, Billet Superlite 6R	2
8	230-9183	Nut, Self-Locking Hex Head	4
9	240-2510	Washer, Flat, 5/8 inch	4
10	230-9078	Stud, 3/8-16 x 3/8-24 x 2.5 long (pre installed in bracket)	4
11	240-1159	Washer, Flat, 7/8 inch	16
12	150-8854K	Pad, BP-10 Compound, Axle Set	1
Optional	220-6746	Braided Stainless Steel Hose Kit (not included)	1

NOTES:

Part Number 230-4572 Rotor Bolt Kit, includes part numbers 230-6737 and 240-2509

Part Number 250-7691 Caliper Bracket Mounting Bolt Kit, includes P/N 230-9183, 230-9078, 240-1159, 240-2510, 240-6320 & 250-7690

Item 3a is an optional item and is included with the "-D" kits. Add "-D" to end of part number when ordering

General Information and Disassembly Instructions

- Installation of this kit should only be performed by individuals experienced in the installation and proper operation of disc brake systems. **Prior to any attempt to install this kit, please check the following to ensure a trouble free installation.**

- Inspect the contents of this kit against the parts list to ensure that all components and hardware are included.

- Verify the year and model of your spindle. This kit is designed for direct bolt-on installation to 1998 through 2002 model year production spindles that were originally equipped with twin piston calipers. This kit will not fit 1993 through 1997 production year spindles originally equipped with single piston floating mount calipers. The correct spindles are identified by casting numbers 18023021 and 18023022. 1993 through 1997 model year vehicles may be updated with the later model spindle to accommodate installation of this kit.

- Verify your wheel clearance using figure 2.

- Verify that the factory hub and stud pattern matches the stud hole pattern in the hats supplied with this kit. Hubs that have been modified with different size studs or lug patterns may require modifications to the hat that must be performed by a qualified machinist.

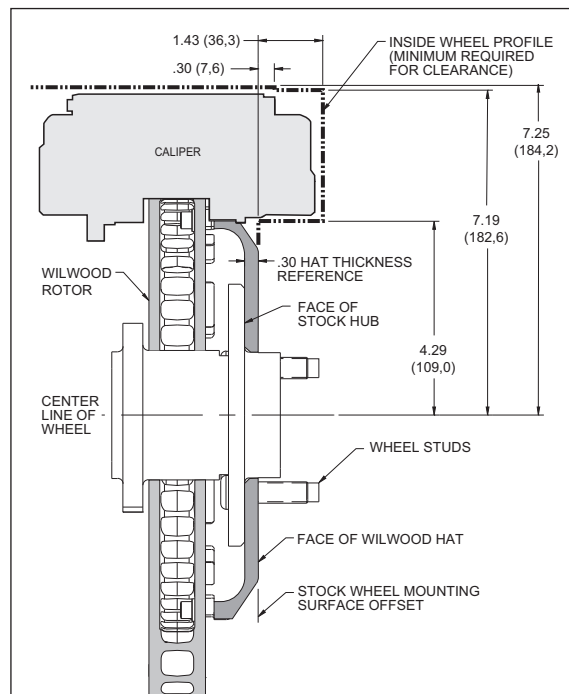

Figure 2. Wheel Clearance Diagram

Disassembly

- Disassemble the original equipment front brakes: Raise the front wheels off the ground. Support the front suspension by placing jack stands under the lower control arms. The lower control arms **MUST** be supported. The vehicle's weight must be on jack stands and not supported by a car jack or hoist.

- Remove the wheel. Remove the two bolts from the backside of the spindle that hold the stock caliper mounting bracket and lift off the bracket and stock caliper as one unit. If space is a problem, you may have to unbolt the stock caliper from the caliper bracket before removal. Save the stock caliper mounting bracket bolts, they will be utilized during reassembly, then slide off the stock hat and rotor assembly. Optional: Removal of the dust face plate to facilitate easy removal of additional parts and/or for aesthetic purposes if you will be running spoked wheels and would like to see the slotted rotor.

- Clean and de-grease the spindles as well as the stock caliper bracket bolts. Remove all nicks or burrs on the spindle snout and threads.

Assembly Instructions

Assembly Instructions (numbers in parenthesis refer to the part list/diagram on the preceding page): **CAUTION:** All mounting bolts must fully engage insert nuts. Be sure to check that all bolts are either flush or protruding through flanged side of insert nut after shimming.

- The caliper mount bracket assembly (1) should be installed first with clean, dry threads on the mounting bolts. Install the bracket using the original caliper mount bolts. The bolts will now pass through the spindle from the opposite direction that they were removed (see figure 1). The bracket must tighten squarely against the inboard side of the caliper mount bosses on the spindle body. Inspect for interference from casting irregularities, machining ridges, burrs, etc. Use one thin shim (2) between the bracket and spindle during initial trial fitting. Later, after the caliper, pad, and rotor alignment has been checked, and any necessary shims have been put in place, the mount bolts should be coated with red *Loctite*® 271 and torqued to 65 ft-lbs.

- Assemble the rotor (3) to the hat (4) with the bolts (6) and washers (5) provided in the configuration pictured in figure 1. Be sure all bolts thread in smoothly and are snug. Then, torque all bolts in an alternating sequence to 85 **in-lbs**. Safety wire bolts (6) using standard 0.032 inch diameter stainless steel safety wire as shown in Figure 3. Please refer to Wilwood's data sheet DS-386 (available at www.wilwood.org/ds386.pdf) for complete safety wire installation instructions.

- Install the hat and rotor assembly onto the hub. Check to be sure the hat seats squarely against the hub. The hub must be free from any rust, debris, casting burrs, machining irregularities, etc. Use several lug nuts to hold the rotor and hat firmly against the hub during the next phases of the installation and clearance checking procedures.

- NOTE:** Please reference the caution statement at the beginning of the assembly instructions. Install one shim (11) over each stud (10) on the radial mount bracket. Slide the caliper (7) in place over the studs and rotors and install the washer (9) and lock nut (8) to hold the caliper in place. The caliper bleed screws should be pointing up. Snug the lock nuts (8) and check that the rotor (3) is centered in the caliper (7). Add or subtract .035" shims (2) as necessary between the mount bracket and the spindle to center the caliper.

- Remove the caliper center bridge pad retainer bolt, nut, and tube from the caliper. Slide the brake pads (12) into place. They should install easily without interference. Check that the outside radius of the brake pad is aligned with the outside diameter radius of the rotor face. Add or subtract shims (11) between the caliper and mount bracket to gain the proper alignment. Reinstall the center bridge pad retainer tube, bolt, and lock nut. The locknut should be snug without play in the bolt or tube. Be cautious not to over tighten.

- Remove the lug nuts that were holding the hat in place. Install the wheel and torque the lug nuts to specification. Check to see that the wheel rotates freely without interference.

- Once all clearances have been checked, remove the wheel, caliper, hat, and rotor from the spindle and hub. Secure the caliper mounting bracket (1) to the spindle using red *Loctite*® 271. Torque the bolts to 65 ft-lbs. Reinstall the hat and rotor assembly and again use several lug nuts to hold it in place. Lubricate caliper mounting studs and nuts with lightweight oil, reinstall the caliper, torque the caliper nuts (8) to 30-35 ft-lbs.

- Install braided flexline kit part number 220-6746 (not included). The 10mm x 1 to -3 (P/N 220-6890) male fitting installs to the stock bulkhead. Then install the straight 1/8-27 to -3 NPT (P/N 220-6956) fitting into the caliper (7). Finally, install the flex line (P/N 220-6411) to the two previously installed fitting. **NOTE:** OEM rubber brake hoses generally cannot be adapted to Wilwood calipers. The caliper inlet fitting is a 1/8-27 NPT. The preferred method is to use steel adapter fittings at the caliper, either straight, 45 or 90 degree and enough steel braided line to allow for full suspension travel and turning radius, lock to lock. **Carefully route lines to prevent contact with moving suspension, brake or wheel components.** Wilwood hose kits are designed for use in many different vehicle applications and it is the installer's responsibility to properly route and ensure adequate clearance and retention for brake hose components.

- Specified brake hose kits may not work with all Years, Makes and Models of vehicle that this brake kit is applicable to, due to possible OEM manufacturing changes during a production vehicle's life. It is the installer's responsibility to ensure that all fittings and hoses are the correct size and length, to ensure proper sealing and that they will not be subject to crimping, strain and abrasion from vibration or interference with suspension components, brake rotor or wheel.

- In absence of specific instructions for brake line routing, the installer must use his best professional judgment on correct routing and retention of lines to ensure safe operation. Test vehicle brake system per the 'minimum test' procedure stated within this document before driving. After road testing, inspect for leaks and interference. Initially after install and testing, perform frequent checks of the vehicle brake system and lines before driving, to confirm that there is no undue wear or interference not apparent from the initial test. Afterwards, perform periodic inspections for function, leaks and wear in a interval relative to the usage of vehicle.

- Repeat the procedure for the other wheel.

- Bleed the brake system. Reference the general information and recommendations on page 5 for proper bleeding instructions.

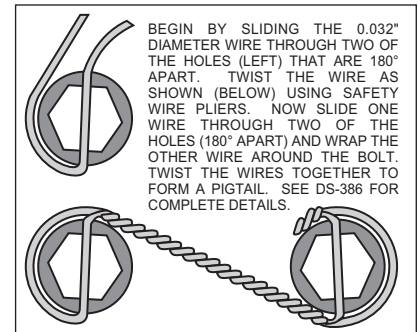

Figure 3. Safety Wire Diagram

Additional Information and Recommendations

- Please read the following concerning balancing the brake bias on 4 wheel disc vehicles.

This brake kit can be operated using the stock OEM master cylinder. However, as with most suspension and tire modifications (from OEM specifications), changing the brakes may alter the front to rear brake bias. Rear brakes should not lock up before the front. Brake system evaluation and tests should be performed by persons experienced in the installation and proper operation of brake systems. Evaluation and tests should be performed under controlled conditions. Start by making several stops from low speeds then gradually work up to higher speeds. Always utilize safety restraint systems while operating vehicle.

Use a Wilwood adjustable proportioning valve if necessary to achieve proper brake balance, or

Use a Wilwood brake pedal/balancebar assembly with dual master cylinders (requires custom mounting as used in fabricated chassis race cars). A balance bar brake system permits incremental front to rear brake pressure adjustments.

- For optimum performance, fill and bleed the new system with Wilwood Hi-Temp° 570 grade fluid or EXP 600 Plus. For severe braking or sustained high heat operation, use Wilwood EXP 600 Plus Racing Brake Fluid. Used fluid must be completely flushed from the system to prevent contamination. **NOTE:** Silicone DOT 5 brake fluid is **NOT** recommended.
- To properly bleed the brake system, begin with the caliper farthest from the master cylinder. Bleed the outboard bleed screw first, then the inboard. Repeat the procedure until all calipers in the system are bled, ending with the caliper closest to the master cylinder. **NOTE:** When using a new master cylinder, it is important to bench bleed the master cylinder first.
- If the master cylinder is mounted lower than the disc brake calipers, some fluid flowback to the master cylinder reservoir may occur, creating a vacuum effect that retracts the caliper pistons into the housing. This will cause the pedal to go to the floor on the first stroke until it has “pumped up” and moved all the pistons out against the pad again. A Wilwood in-line two pound residual pressure valve, installed near the master cylinder will stop the fluid flowback and keep the pedal firm and responsive..

For all types of pedals and master cylinders:

- Test the brake pedal. It should be firm and consistent. If not, first try re-bleeding the system. The pedal should stop at least 1" or more from the floor under heavy load. Pedal height must be comfortable to the driver.
- If the pedal is initially firm, but then travels to the floor, check the entire system for leaks. This may also be a sign of a faulty master cylinder.
- If the pedal is constantly spongy, and repeated bleeding does not correct the problem, the master cylinder selection and pedal geometry may need re-evaluated.
- If you are still experiencing difficulty after all instructions have been followed, consult your chassis shop, the retailer where the kit was purchased, or the Wilwood Tech Line.

Brake Testing and Pad Bedding

WARNING • DO NOT DRIVE ON UNTESTED BRAKES BRAKES MUST BE TESTED AFTER INSTALLATION OR MAINTENANCE MINIMUM TEST PROCEDURE

- Make sure pedal is firm: Hold firm pressure on pedal for several minutes, it should remain in position without sinking. If pedal sinks toward floor, check system for fluid leaks. DO NOT drive vehicle if pedal does not stay firm or can be pushed to the floor with normal pressure.
- At very low speed (2-5 mph) apply brakes hard several times while turning steering from full left to full right, repeat several times. Remove the wheels and check that components are not touching, rubbing, or leaking.
- Carefully examine all brake components, brake lines, and fittings for leaks and interference.
- Make sure there is no interference with wheels or suspension components.
- Drive vehicle at low speed (15-20 mph) making moderate and hard stops. Brakes should feel normal and positive. Again check for leaks and interference.
- Always test vehicle in a safe place where there is no danger to (or from) other people or vehicles.
- Always wear seat belts and make use of all safety equipment.

New Rotor Bedding:

- Make a series of light, then medium, then gradually harder stops to bring the rotors up to near operating temperature. Then use a few cool down laps to allow the rotors to cool. Avoid using the brakes during the cool down. This will act as the final stress relief on the rotors. If possible, allow the rotors to cool completely before competition and subsequent pad bedding. Be cautious to avoid heat shocking the rotors by heating or cooling them too quickly when they are new. It is also a good practice to warm the brakes prior to any competition to avoid thermal shock and potential stress fractures.

New Pad Bedding:

- This procedure is similar to the rotor bedding process. Make a series of light, then medium, then gradually harder stops to bring the pads to full operating temperature. Then use a few cool down laps to allow the pads to cool. Avoid using the brakes during the cool down. If possible, allow the brakes to cool completely before participating in competition. This process will properly mate the pads with the rotor surface and act as the final curing step for the friction compound. Following this procedure will assure the best performance and service life from your brakes.

Associated Components

PART NO.	DESCRIPTION
260-1874	Wilwood Residual Pressure Valve (2 lb for disc brakes)
260-8419	Wilwood Proportioning Valve, Knob Style
260-8420	Wilwood Proportioning Valve, Lever Style
290-6209	Wilwood Racing Brake Fluid (EXP 600 Plus) (16.9 oz)
340-1285	Wilwood Floor Mount Brake Pedal (with balance bar)
340-1287	Wilwood Swing Mount Brake Pedal (with balance bar)
260-3376	Wilwood 7/8 inch Bore Combination Master Cylinder
260-5920	Wilwood 13/16 inch Bore Combination Master Cylinder
260-8555	Wilwood 1 inch Aluminum Tandem Chamber Master Cylinder
260-8556	Wilwood 1-1/8 inch Aluminum Tandem Chamber Master Cylinder
15A-5938K	PolyMatrix 7420 "A" Compound Brake Pads
15B-5939K	PolyMatrix 7420 "B" Compound Brake Pads
130-5972	Caliper O-Ring Seal Kit
(Consult the Wilwood Tech Manual for a complete parts list)	

Bolt Torque Specifications

BOLT SIZE	TORQUE
1/4-20	85 in-lb
1/4-28	103 in-lb
5/16-18	180 in-lb
5/16-24	198 in-lb
3/8-16	22 ft-lb
3/8-24	30 ft-lb
7/16-14	42 ft-lb
7/16-20	47 ft-lb
1/2-13	65 ft-lb
1/2-20	77 ft-lb
9/16-12	95 ft-lb
9/16-18	105 ft-lb
5/8-11	110 ft-lb
5/8-18	120 ft-lb
NOTE: This bolt torque specification list is for use with specific grades of bolts as supplied in the particular Wilwood kit and is not intended as a guide for any other application.	